

# AZUD HELIX AUTOMATIC



**In-line Self Cleaning Equipment with disc filtering elements and 3" valves.**

**High density polyethylene manifolds. Easy to install. Maximum resistance and durability. Max. flow: 768 m<sup>3</sup>/h (3381 gpm).**

Modular configurations can be designed to customer preference or space availability. Automation available in 120 V, 220 V or 12 V. Design solutions also available for high or low pressure and sea water/saline water. Compressed air can be used for backwashing.

## TECHNOLOGY

AZUD HELIX AUTOMATIC backwashes one station at a time. Remaining elements continue filtering.

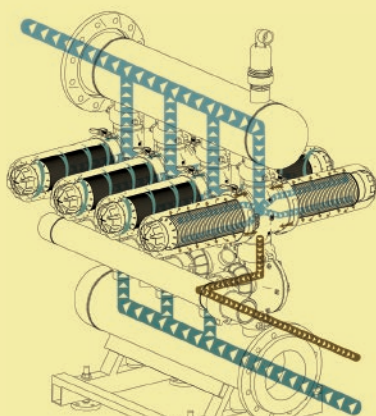

**FILTRATION STAGE:** The Helix generates a centrifugal helical effect upon entry into the filter, this moves the particles away from the discs.

The water then passes efficiently through the depth of the uniquely designed discs.

**BACKFLUSHING STAGE:** The clean water from the auxiliary filter is introduced from the reverse direction through the filtering element. This decompresses the stack of discs, allowing the discs to separate and backwash efficiently. The solids are expelled from the discs and evacuated through the backwash manifold. The filtration process then restarts with the compression of the discs.

The backwash is controlled by two valves and a controller, which integrate the filtration equipment.

## ADVANTAGES

- ✓ **Disc Filtration. Maximum safety.**  
Its patented design and high quality materials used in manufacturing guarantee an extended life with high resistance.
- ✓ **AZUD HELIX SYSTEM.**  
Helix created Centrifugal Action optimizes the filtration performance and reduces backwash frequency and maintenance.
- ✓ **Self-cleaning filtering element.**  
Backwashing uses minimal water maintaining an efficient cleaning action. Large filtering surface. AZUD filtration units available from 5 to 500 micron.



- ✓ **Modularity, Versatility, Compatibility.**  
The system permits a wide range of flows and configurations using a minimal number of components.
- ✓ **Compact assembled systems for easy transportation and installation.**
- ✓ **Manufactured in plastic materials.**
- ✓ **Low Maintenance.**  
No tools required. Maximum wear resistance of high quality moving parts.
- ✓ **Water and energy saving.**

# AZUD HELIX AUTOMATIC

**FILTRATION** Maximum flow per filter  
 AZUD HELIX AUTOMATIC filter filtering surface 2984 cm<sup>2</sup> / 463 in<sup>2</sup>

QUALITY OF WATER	micron mesh	400 - 200 40 - 75	130 120	100 150	50	20
GOOD	m <sup>3</sup> /h gpm	72 314	64 282	48 211	34 154	18 76
AVERAGE	m <sup>3</sup> /h gpm	63 279	59 261	40 176	28 122	14 62
POOR	m <sup>3</sup> /h gpm	51 226	47 209	36 158	20 92	10 46
VERY POOR	m <sup>3</sup> /h gpm	32 139	28 122	24 106	14 62	6 30

## BACKFLUSHING

	400 - 200 - 130 micron 40 - 75-120 mesh	100 micron 150 mesh	50-20 micron
Minimum backflushing pressure per filter 4"	2.8 bar	3.5 bar	4 bar
	40 psi	50 psi	58 psi
Minimum backflushing flow per filter 4"	5 l/s	6.2 l/s	6.6 l/s
	78 gpm	100 gpm	104 gpm

### HOW TO CHOOSE AZUD HELIX AUTOMATIC EQUIPMENTS

1. Determine the required filtration grade (micron).
2. Establish the quality of the water.
3. Calculate according to the following equation, the numbers of filters required with the selected SERIES.

$$\text{Number of filters} = \frac{\text{Flow to filter in the installation}}{\text{Max. Flow per filter}}$$

NOTE : The flow rate given by the filter conditions determines the frequency of the backwashing.

### MATERIAL

Manifolds	High Density Polyethylene
Housing	Polyamide reinforced with fiberglass
Filtering element	PP grooved discs
Sealing element	NBR
Backflushing valve	Plastic

pH>4 • Maximum pressure 10 bar / 145 psi • Maximum temperature 60°C / 140 F

### AZUD HELIX AUTOMATIC HEAD LOSS

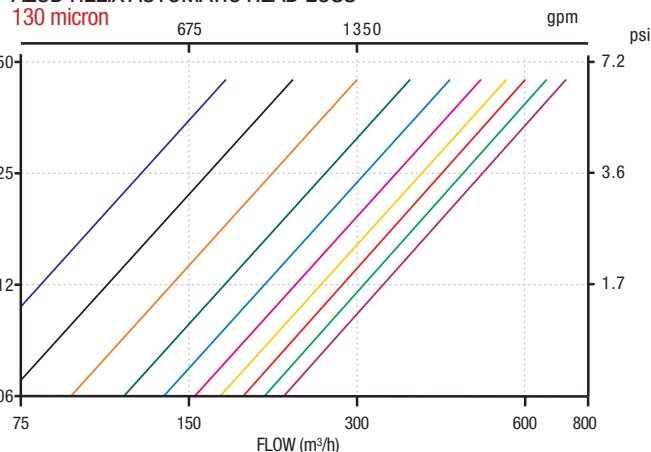

Model	Specifications				Dimensions (mm)															
	N. Filters	Manifold	Filtering Surface (cm <sup>2</sup> )	(in <sup>2</sup> )	F mm	F in	E mm	E in	D mm	D in	L mm	L in	R mm	R in	T mm	T in	S mm	S in	H mm	H in
4DCL3/6FX	4" x 3	6"-150	8952	1388	888	35	277	11	930	37	1060	42	605	24	300	12	1188	47	1705	67
4DCL4/6FX	4" x 4	6"-150	11936	1850	888	35	277	11	1145	45	1305	51	605	24	300	12	1188	47	1705	67
4DCL4/8FX	4" x 4	8"-200	11936	1850	928	37	277	11	1195	47	1300	51	645	25	320	13	1248	49	1785	70
4DCL5/6FX	4" x 5	6"-150	14920	2313	888	35	277	11	1420	56	1580	62	605	24	300	12	1188	47	1705	67
4DCL5/8FX	4" x 5	8"-200	14920	2313	928	37	277	11	1470	58	1580	62	645	25	320	13	1248	49	1785	70
4DCL6/8FX	4" x 6	8"-200	17904	2775	928	37	277	11	1745	69	1855	73	645	25	320	13	1248	49	1785	70
4DCL6/10FX	4" x 6	10"-273	17904	2775	978	39	277	11	1779	70	1870	74	700	28	350	14	1328	52	1890	74
4DCL7/8FX	4" x 7	8"-200	20888	3238	928	37	277	11	2259	89	2343	92	645	25	320	13	1248	49	1785	70
4DCL7/10FX	4" x 7	10"-273	20888	3238	978	39	277	11	2259	89	2346	92	700	28	350	14	1328	52	1890	74
4DCL8/8FX	4" x 8	8"-200	23872	3700	928	37	277	11	2474	97	2558	101	645	25	320	13	1248	49	1785	70
4DCL8/10FX	4" x 8	10"-273	23872	3700	978	39	277	11	2474	97	2561	101	700	28	350	14	1328	52	1890	74
4DCL9/10FX	4" x 9	10"-273	26856	4163	978	39	277	11	2749	108	2837	112	700	28	350	14	1328	52	1890	74
4DCL9/12FX	4" x 9	12"-323.9	26856	4163	1043	41	277	11	2749	108	2837	112	773	30	390	15	1433	56	2030	80
4DCL10/10FX	4" x 10	10"-273	29840	4625	978	39	277	11	3024	119	3108	122	700	28	350	14	1328	52	1890	74
4DCL10/12FX	4" x 10	12"-323.9	29840	4625	1043	41	277	11	3024	119	3112	123	773	30	390	15	1433	56	2025	80
4DCL11/12FX	4" x 11	12"-323.9	32824	5088	1043	41	277	11	3299	130	3387	133	773	30	390	15	1433	56	2025	80
4DCL12/12FX	4" x 12	12"-323.9	35808	5550	1043	41	277	11	3574	141	3662	144	773	30	390	15	1433	56	2025	80
4DCH3/8FX	4" x 3	8"-200	8952	1388	958	38	292	11	980	39	1060	42	660	26	320	13	1278	50	1815	71
4DCH4/8FX	4" x 4	8"-200	11936	1850	958	38	292	11	1195	47	1300	51	660	26	320	13	1278	50	1815	71
4DCH5/10FX	4" x 5	10"-273	14920	2313	1008	40	292	11	1504	59	1595	63	715	28	350	14	1358	53	1920	76
4DCH6/10FX	4" x 6	10"-273	14920	2313	1008	40	292	11	1779	70	1870	74	715	28	350	14	1358	53	1920	76
4DCH7/10FX	4" x 7	10"-273	20888	3238	1008	40	292	11	2259	89	2343	92	715	28	350	14	1358	53	1920	76
4DCH8/12FX	4" x 8	12"-323.9	23872	3700	1073	42	292	11	2474	97	2561	101	788	31	390	15	1463	58	2055	81
4DCH9/12FX	4" x 9	12"-323.9	26856	4163	1073	42	292	11	2749	108	2837	112	788	31	390	15	1463	58	2055	81
4DCH10/12FX	4" x 10	12"-323.9	29840	4625	1073	42	292	11	3024	119	3112	123	788	31	390	15	1463	58	2055	81
4DCH11/12FX	4" x 11	12"-323.9	32824	5088	1073	42	292	11	3299	130	3387	133	788	31	390	15	1463	58	2055	81

W=1200 mm (47 in)

Drainage Manifold included - Grooved connection.  
 Dimensions of the models with flange connection.  
 Other configurations in www.azud.com

### AZUD HELIX AUTOMATIC SERIE 4DCL / 4DCH

